

Tracker at 60 degrees tilt angle

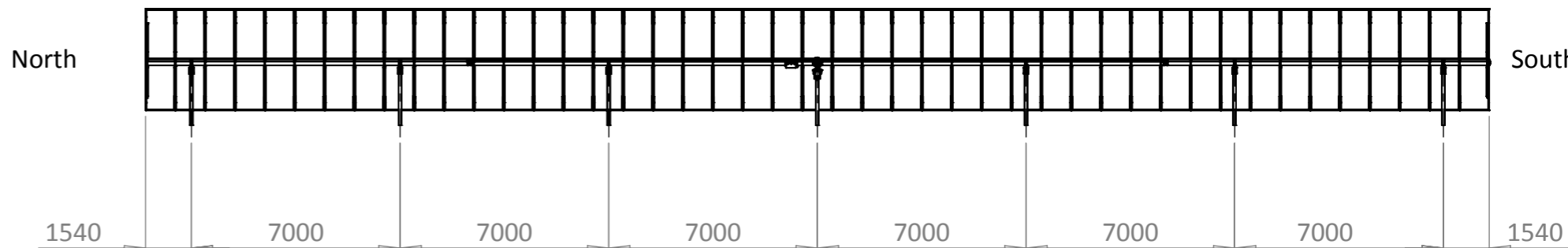

Tracker at horizontal position

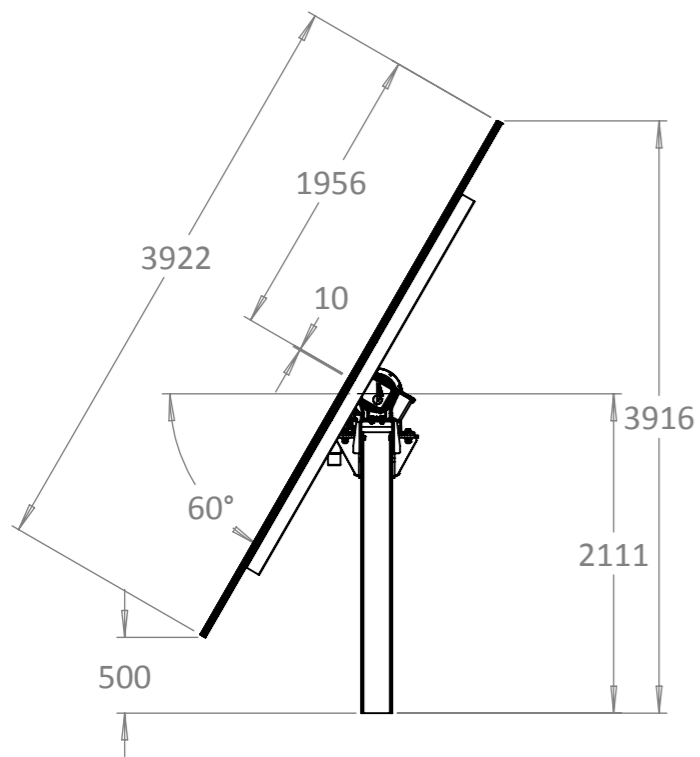
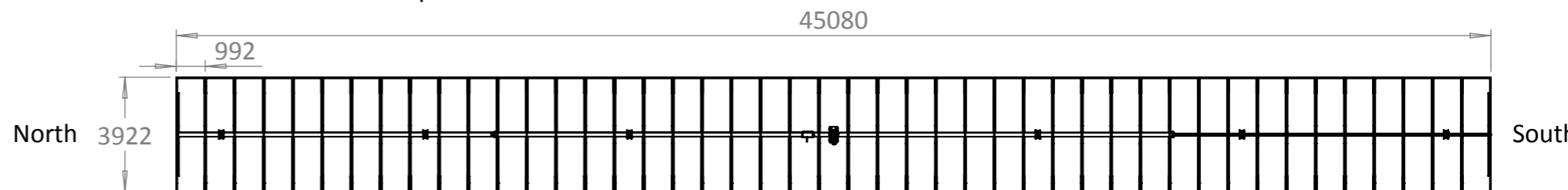

Motor support

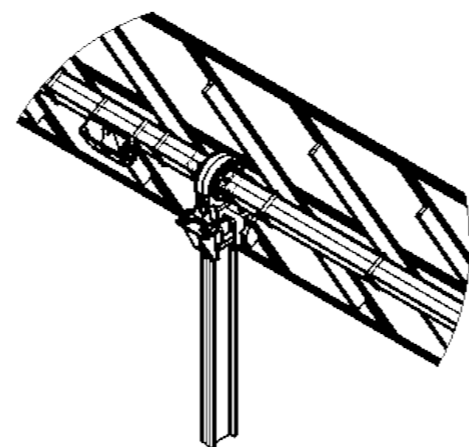

DETAIL A
ESCALA 1 : 50

Simple support

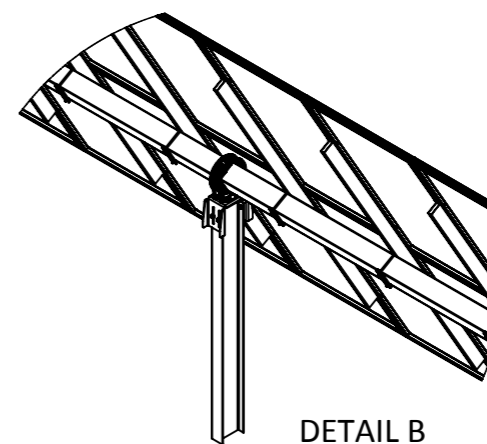

DETAIL B
ESCALA 1 : 50

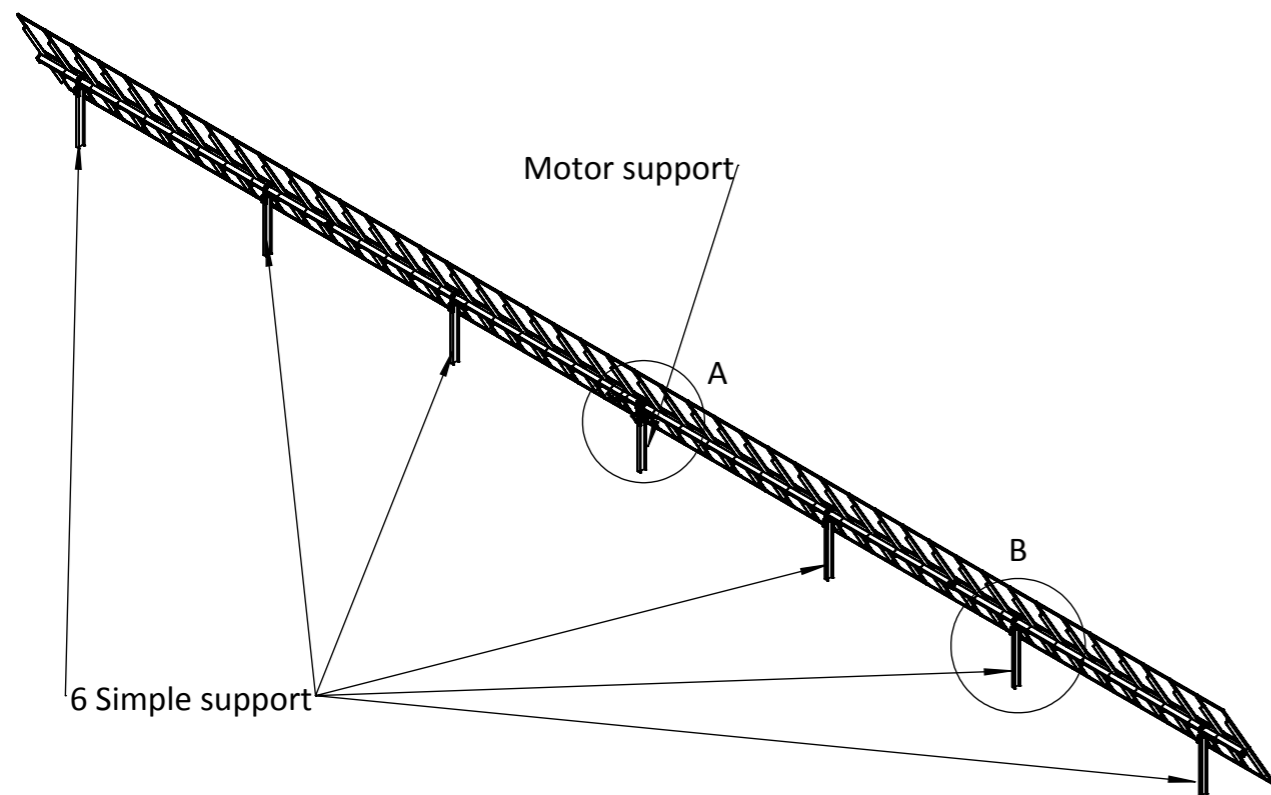

Rev.	Description	Signee	Date
-	-	-	-
-	-	-	-
-	-	-	-
<p>MANUFACTURING GENERAL NOTES</p> <p>DIMENSIONAL & GEOMETRICAL GENERAL TOLERANCES WITHOUT INDIVIDUAL TOLERANCE INDICATION, BASED ON ISO 2768-mk.</p> <p>WELDING GENERAL TOLERANCES BASED ON ISO 13920 & WELDING SYMBOLS IN ACCORDANCE WITH ISO 2553.</p> <p>SURFACE FINISH SYMBOLS IN ACCORDANCE WITH ISO 1302-ISO/R 468.</p> <p>EXCEPT INDICATION DIMENSIONS IN MM & WEIGHTS IN KG.</p>		<p>PROPRIETARY AND CONFIDENTIAL</p> <p>THE INFORMATION CONTAINED IN THIS DRAWING IS THE SOLE PROPERTY OF SOLTEC. ANY REPRODUCTION IN PART OR AS A WHOLE WITHOUT THE WRITTEN PERMISSION OF SOLTEC IS PROHIBITED.</p>	
<p>APPLY</p> <p>x</p>		<p>Material</p> <p>Según LDM</p>	
<p>Weight (kg)</p>		<p>Lyfecycle</p> <p>-</p>	
<p>Name</p> <p>AJR</p>		<p>Date</p> <p>02/06/17</p>	
<p>Created</p>		<p>Description</p> <p>SF7 2x45</p>	
<p>Checked</p>		<p>Finish</p> <p>-</p>	
<p>Appr.</p>		<p>Dwg. no.</p> <p>SF7-05</p>	
<p>Scale</p> <p>1:200</p>		<p>Drawing method:</p>	
<p>Page 1 of 1</p>		<p>Rev.</p> <p>-</p>	
<p>A3</p>		<p>Page 1 of 1</p>	

